

InFrame™ Interior Framing System

Brings Beauty and Expertise to the Inside



Open space is one of the most desired features in today's commercial buildings, and design professionals are incorporating broad expanses of glass into interior spaces. Kawneer is bringing its expertise inside with InFrame™ Interior Framing. Able to be configured to meet various project requirements, InFrame™ Interior Framing is sturdy yet adaptable and allows more light to fill interior spaces.

Available as screw-spline construction and a center-aligned glass pane, InFrame™ Interior Framing meets the design needs of a range of building applications – both new and retrofit construction. With Kawneer as a single source for both exterior and interior framing and InFrame™'s break through design, performance and beauty, walls are no longer barriers.

Performance

InFrame™ Interior Framing System brings the proven performance and expertise of Kawneer exterior framing products inside. The system is easily configured to meet a vast array of project requirements and is available as screw-spline construction and flush-glazed, center-aligned glass. It accommodates 1/4" infill within 2" x 6" sightlines. InFrame™ Interior Framing is sturdy, yet adaptable, with a full-perimeter bulb gasket designed to capture drywall and accommodate variations in drywall thickness, allowing for common inconsistencies, including screw heads and uneven mudding.

InFrame™ Interior Framing is engineered to integrate easily with Kawneer entrances, allowing seamless incorporation of our standard or speciality entrances. Delivering the quality and knowledge Kawneer is known for, architects, contractors and owners can be assured of structural integrity and solid performance levels for both interior and exterior framing, ensuring consistency throughout the project – from design to installation.

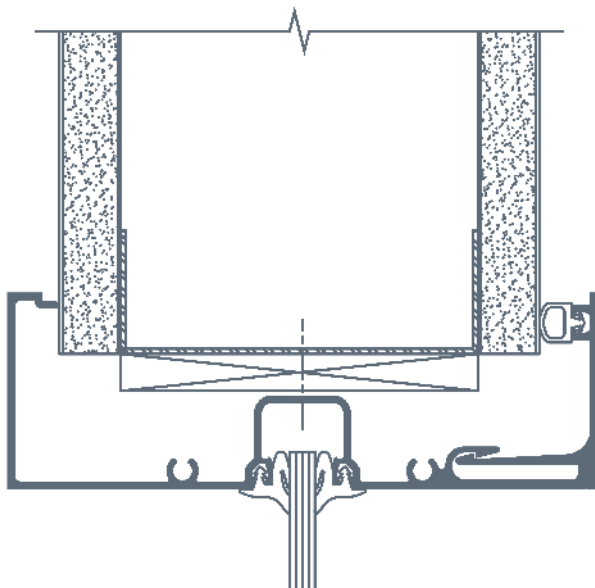

InFrame™ Interior Framing System captures standard commercial drywall and uses wraparound perimeter profiles with a bulb gasket design to provide additional adjustments for drywall thickness variations.

Fabrication and Installation

Screw-spline fabrication, a foundation for many of Kawneer's exterior products, means configurations of InFrame™ Interior Framing are easy to fabricate and contractors can leverage existing installation experience and knowledge. Two-piece perimeter profiles that capture drywall simplify and speed the installation process.

Aesthetics

A selection of features come together to deliver streamlined, open interiors, making InFrame™ Interior Framing an excellent option for architects, designers and owners. Wraparound perimeter profiles deliver clean lines and eliminate the need to finish drywall terminations. InFrame™ transitions seamlessly from fixed framing to operable doors, providing enhanced design flexibility. An optional 4" tall sill member is available for a greater range of design possibilities for specific project requirements and architectural styles.

For the Finishing Touch

InFrame™ Interior Framing is available in anodized finishes and fluoropolymer painted finishes in a variety of colors.

All anodic finishes by Kawneer meet the requirements of the Aluminum Association DAF-45 and AAMA 611 for anodized architectural aluminum. Fluoropolymer finishes meet or exceed the AAMA 2604 specification.

Solvent-free powder coatings add the "green" element with high performance durability and scratch resistance that meet the standards of AAMA 2604.

Kawneer Company, Inc.
Technology Park / Atlanta
555 Guthridge Court
Norcross, GA 30092

kawneer.com
kawneergreen.com
770 . 449 . 5555

