

USE THESE INSTRUCTIONS IN CONJUNCTION WITH INSTALLATION INSTRUCTIONS 162-970.

### PERIMETER ANCHORING

TO CALCULATE END REACTIONS

$$\frac{\text{MODULE(FT)} \times \text{LENGTH(FT)} \times \text{WIND LOAD(PSF)}}{2}$$

EQUALS END REACTION IN POUNDS

EXAMPLE  $\frac{5' \times 7' \times 20 \text{ PSF}}{2} = 350\#$

**A** IF THE END REACTION IS 350# OR LESS THE FOLLOWING PERIMETER ANCHORING USING "F" PERIMETERS CAN BE USED.

USE GLAZING TEMPORARIES TO HOLD FRAMING MEMBERS TO PERIMETERS UNTIL PRESSURE PLATES ARE INSTALLED.

PERIMETER FASTENER 24" ON CENTER OR AS REQUIRED

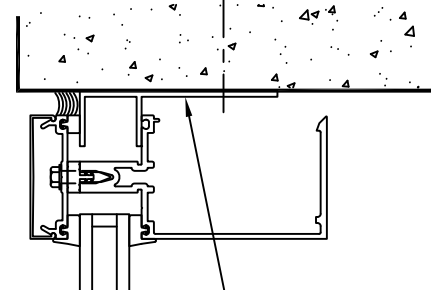

162-017 "F" PERIMETER AT 1" FRAMING  
162-176 AT 1/4" FRAMING

HEAD AND SILL CONDITIONS WITH FINISHED INTERIORS

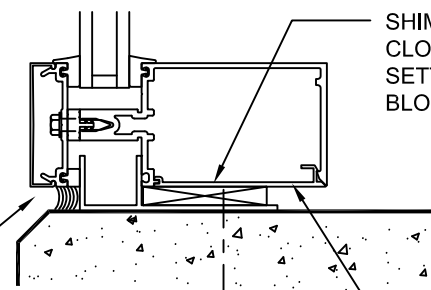

SHIM SILL CLOSE TO SETTING BLOCKS

DO NOT LET PERIMETER SEAL COVER WEEP HOLES

SNAP-IN SHIM SUPPORTS  
162-316 6" SYSTEM  
162-317 7-1/2" SYSTEM

**A** IF THE END REACTION IS 350# OR LESS THE FOLLOWING PERIMETER ANCHORING USING "F" PERIMETERS CAN BE USED.

162-017 "F" PERIMETER AT 1" FRAMING  
162-176 AT 1/4" FRAMING

PERIMETER FASTENER 24" ON CENTER OR AS REQUIRED

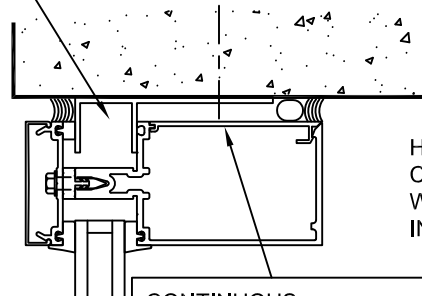

HEAD AND SILL CONDITIONS WITH EXPOSED INTERIORS

CONTINUOUS SNAP-IN FILLER  
162-021 6" SYSTEM  
162-020 7-1/2" SYSTEM  
LENGTH EQUALS DLO MINUS 3-1/2" WHEN SHEAR BLOCKS ONLY OCCUR.  
LENGTH EQUALS DLO MINUS 9" WHEN "F" AND "T" ANCHORS OCCUR.

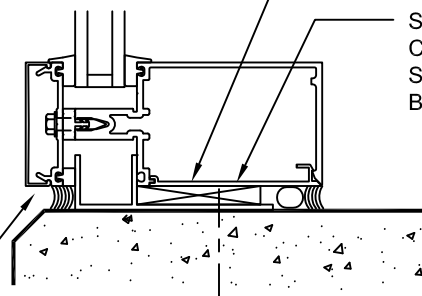

SHIM SILL CLOSE TO SETTING BLOCKS

DO NOT LET PERIMETER SEAL COVER WEEP HOLES

SNAP-IN FILLER AND SEAL ONLY REQUIRED AT VISION AREAS

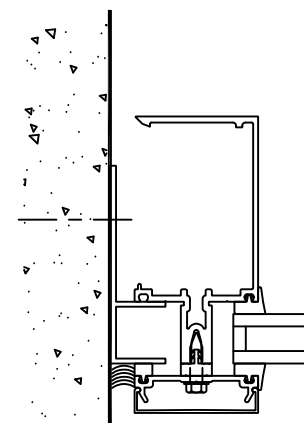

JAMB CONDITION AT FINISHED INTERIOR

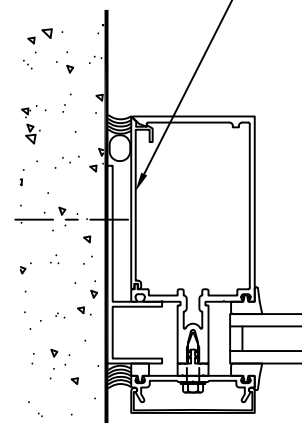

JAMB CONDITION AT EXPOSED INTERIOR

TUBULAR MULLIONS MAY ALSO BE USED AT JAMBS

**B** IF THE END REACTION IS 350# TO 750# THE FOLLOWING PERIMETER ANCHORING CAN BE USED.

DRILL 1/2" DIA. HOLE FOR HOLE PLUGS. DRILL CLEARANCE HOLE FOR 1/4" FASTENER. MAXIMUM FASTENER SPACING IS 24". SEE BELOW FOR ADDITIONAL HEAD AND SILL FASTENERS.

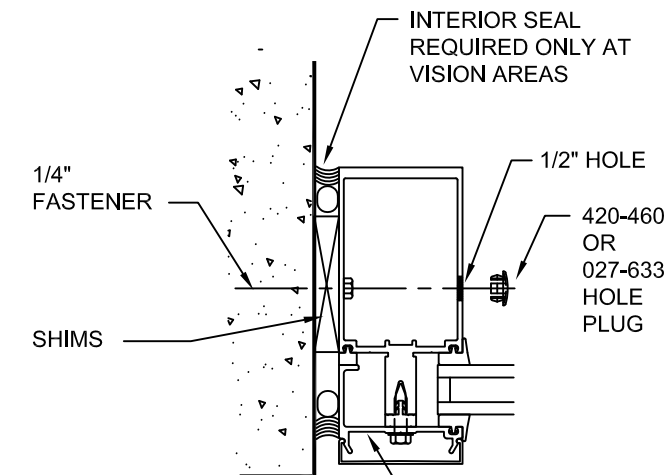

PERIMETER PRESSURE PLATE  
162-505 1" FRAMING  
162-506 1/4" FRAMING  
REFERENCE FABRICATION DETAILS SHEET #2.

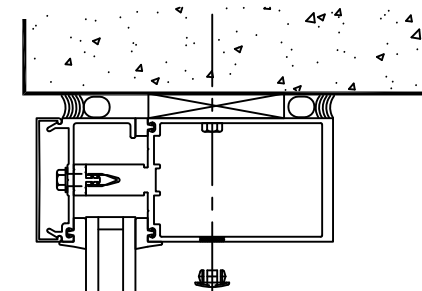

AT PERIMETER PRESSURE PLATES TOP AND BOTTOM END CAPS REQUIRED FOR ALL VERTICALS REFERENCE INSTRUCTIONS 162-970

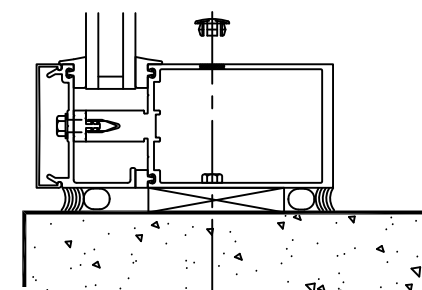

**B** IF THE END REACTION IS 350# TO 750# THE FOLLOWING PERIMETER ANCHORING CAN BE USED.

AT THE HEAD AND SILL, INSTALL FASTENERS 6" EACH SIDE OF VERTICALS AND NO MORE THAN 24" ON CENTER. AT LEAST 3 FASTENERS ARE REQUIRED PER LITE OPENING.

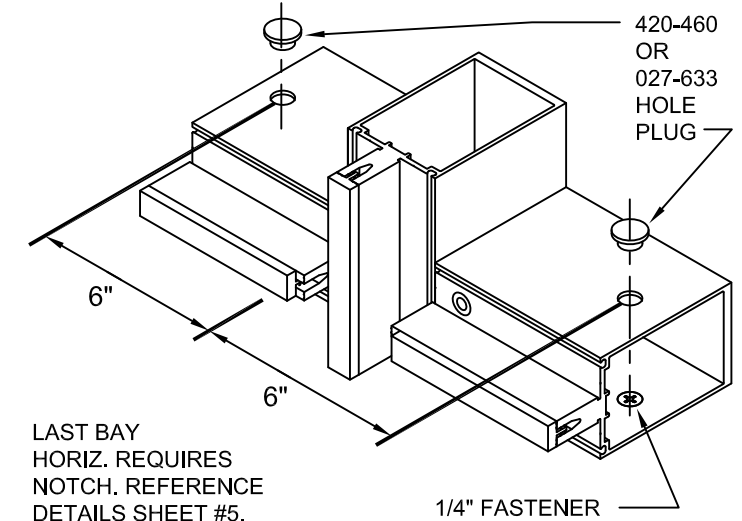

LAST BAY HORIZ. REQUIRES NOTCH. REFERENCE DETAILS SHEET #5.

THIS ANCHORING PROVIDES ADEQUATE SUPPORT FOR THE WALL PROVIDED THE END REACTION AT THE VERTICALS DOES NOT EXCEED 750#. HOWEVER, THE PERIMETER STRUCTURE AND THE PERIMETER FASTENERS ABILITY TO CARRY THE LOAD MUST BE CHECKED PER JOB. CONTACT FACTORY ENGINEERING FOR ASSISTANCE.

PERIMETER PRESSURE PLATES CAN BE USED WITH "F" AND "T" ANCHORS REFERENCE SHEET #2



1600 SYSTEM  
STOCK LENGTH INSTRUCTIONS

PART NUMBER  
162-960 1 OF 5

95449-094  
04/26/13

DRAWING:

ORDER:

SHT:

USE THESE INSTRUCTIONS IN CONJUNCTION WITH INSTALLATION INSTRUCTIONS 162-970.

### PERIMETER ANCHORING

**C** IF THE END REACTION IS 750# AND GREATER "F" AND "T" ANCHORS ARE REQUIRED AT EACH VERTICAL. PERIMETER MEMBERS MAY BE ANCHORED AS SHOWN IN METHODS "A" OR "B" DEPENDING UPON THE JOB CONDITIONS.

"F" OR "T" ANCHORS SHOULD NOT BE USED IN CONDUCTION WITH STEEL REINFORCING WITHOUT CHECKING THE STRUCTURAL INTEGRITY OF THE ANCHORS. CONTACT FACTORY ENGINEERING FOR ASSISTANCE.

"F" ANCHORS CAN NOT BE USED WITH OPEN BACK VERTICAL JAMBS.

"F" ANCHOR FOR JAMBS  
162-308 AT 6" SYSTEM  
162-311 AT 7 1/2" SYSTEM  
162-354 AT 10 1/2" SYSTEM

"T" ANCHOR FOR INTERMEDIATE VERTICAL  
162-309 AT 6" SYSTEM  
162-312 AT 7 1/2" SYSTEM  
162-355 AT 10 1/2" SYSTEM

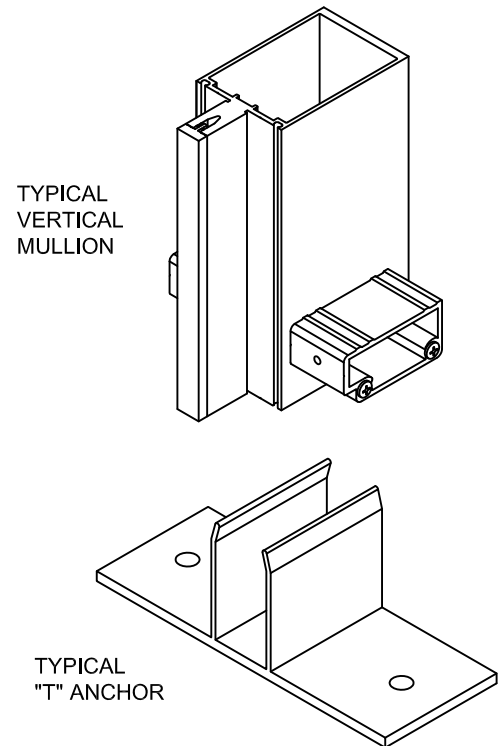

FASTENER PREPS AS REQUIRED. CONTACT FACTORY ENGINEERING FOR ASSISTANCE.

**D** HEAD/SILL SHEAR BLOCK/ANCHORS. REFERENCE STEP #4, SHEET #2, AND STEP #7, SHEET #3 IN THE 162-970 INSTALLATION INSTRUCTIONS.

STRUCTURAL INTEGRITY OF ANCHOR AND FASTENERS MUST BE CHECKED BY FACTORY ENGINEERS.

PERIMETER MEMBERS MAY BE ANCHORED AS SHOWN IN METHODS "A" OR "B" DEPENDING UPON THE JOB CONDITIONS.

USE THIS SHEAR BLOCK WITH OPEN BACK HORIZONTALS WHEN POSSIBLE. IF TUBULAR HORIZONTALS ARE USED A NOTCH IS REQUIRED. REFERENCE FABRICATION DETAILS ON SHEET #4.

VERTICAL HOLE PREPS ARE THE SAME AS TYPICAL SHEAR BLOCKS.

STRUCTURAL SHIMMING IS REQUIRED AT SILL TO ACCOMPLISH DESIGNED PERIMETER SEAL WIDTH.

JAMB SHEAR BLOCK/ANCHOR  
162-314 AT 6" SYSTEM  
162-315 AT 7 1/2" SYSTEM

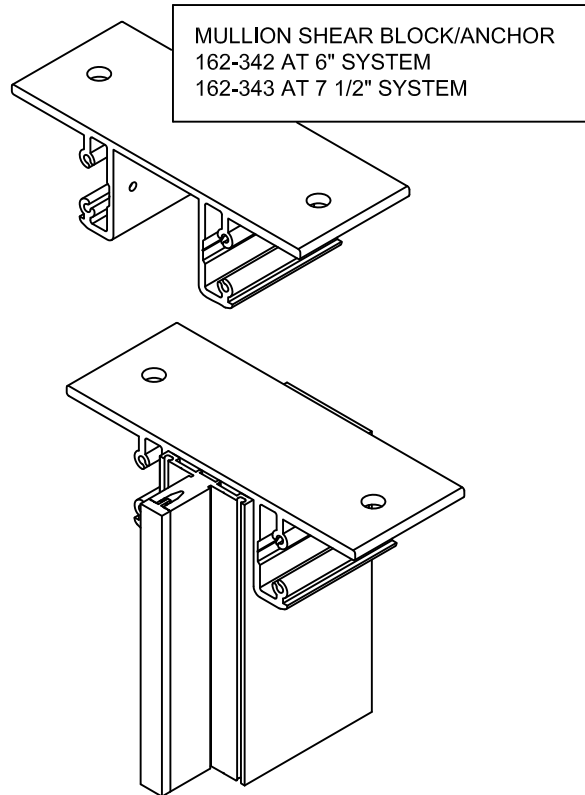

### REFERENCE INSTALLATION INSTRUCTION 162-983

#### EXTERIOR FRAME PERIMETERS

WHEN USING "F" AND "T" ANCHORS SHOWN FOR PERIMETER ANCHORING "C", THE FOLLOWING PERIMETER FRAMING CAN BE USED AT THE HEAD AND SILL ONLY. "F" ANCHORS REQUIRE TUBULAR VERTICAL MULLIONS AT JAMBS.

BUT CAN NOT BE USED WITH SHEAR BLOCK/ANCHOR SHOWN FOR PERIMETER ANCHORING "D".

USE SHEAR BLOCKS  
162-384 6" SYSTEM  
162-385 7 1/2" SYSTEM

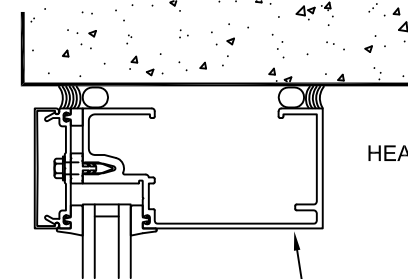

PERIMETER FRAME  
162-203 1" FOR 6" SYSTEM  
162-204 1" FOR 7 1/2" SYSTEM  
162-205 1/4" FOR 6" SYSTEM  
162-206 1/4" FOR 7 1/2" SYSTEM

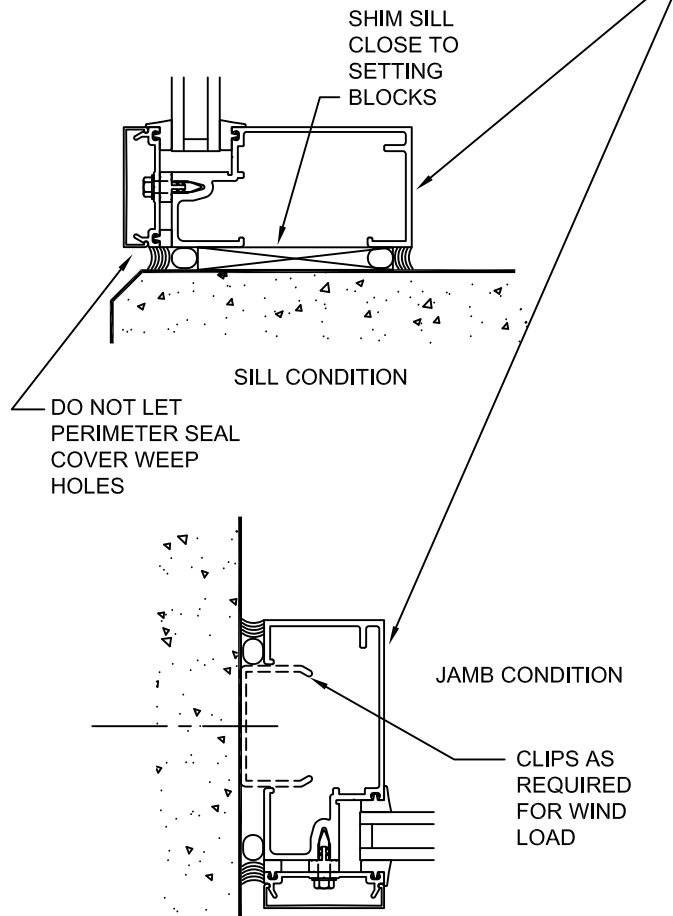

### PRESSURE PLATE FABRICATION

LENGTH OF HORIZONTAL PRESSURE PLATE EQUALS DAYLITE OPENING MINUS 3/4".

ATTACHMENT HOLES ARE FACTORY PUNCHED AT 3" ON CENTER. .266 DIA.(H DRILL).

WEEP HOLES ARE TO BE LOCATED 3-5/8" FROM EACH END AS SHOWN DRILL 5/16" HOLES

FOR FIBERGLASS PRESSURE PLATES:  
FOR BEST RESULTS OPERATOR MUST USE SHARP 3 FLUTE HIGH STRENGTH STEEL OR COBALT DRILL OR CARBIDE "PINEAPPLE CUT" TOOL.

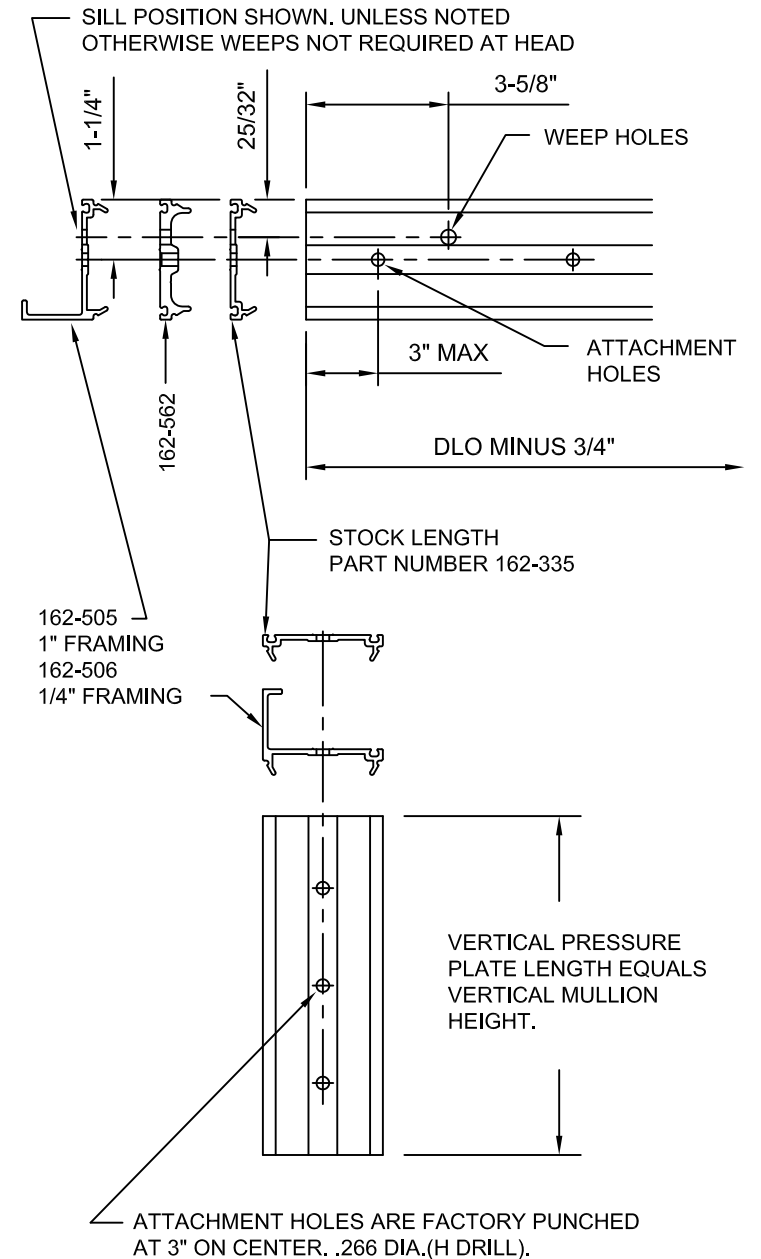

1600 SYSTEM<sup>1</sup>  
STOCK LENGTH INSTRUCTIONS

PART NUMBER  
162-960 2 OF 5

95449-098  
04/04/14

DRAWING:

ORDER:

SHT:

### EXTERIOR COVER FABRICATION

LENGTH OF HORIZONTAL COVER  
EQUALS DAYLITE OPENING MINUS 1/16".

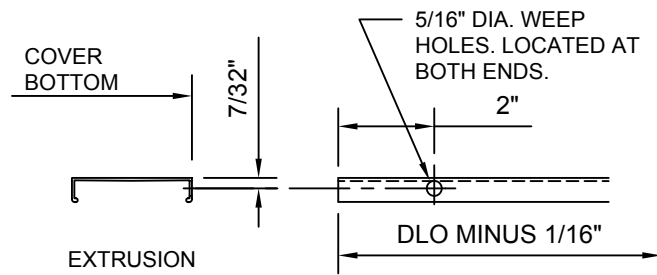

EXTRUSION  
162-006

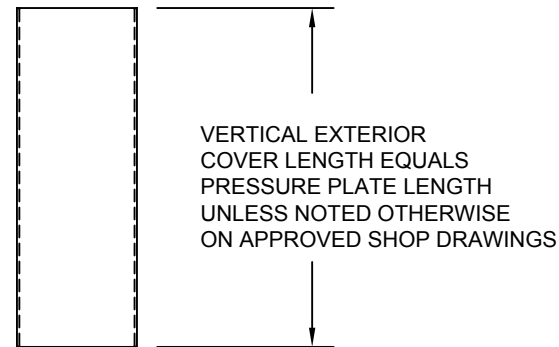

VERTICAL EXTERIOR  
COVER LENGTH EQUALS  
PRESSURE PLATE LENGTH  
UNLESS NOTED OTHERWISE  
ON APPROVED SHOP DRAWINGS

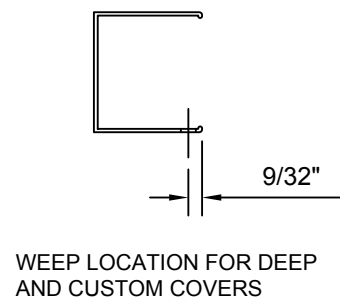

WEEP LOCATION FOR DEEP  
AND CUSTOM COVERS

### VERTICAL MULLION FABRICATION

REFERENCE APPROVED SHOP DRAWINGS FOR  
VERTICAL LENGTHS AND HORIZONTAL LOCATIONS.  
SPLICE FIXNG SCREW, STOP SCREW AND JAMB  
SIDE F-ANCHOR ALIGNMENT PREPS ARE ALL  
SIMILAR TO PREPS NOTED BELOW. REFERENCE  
SHOP DRAWINGS AND 162-970 INSTRUCTIONS.

6" SYSTEM

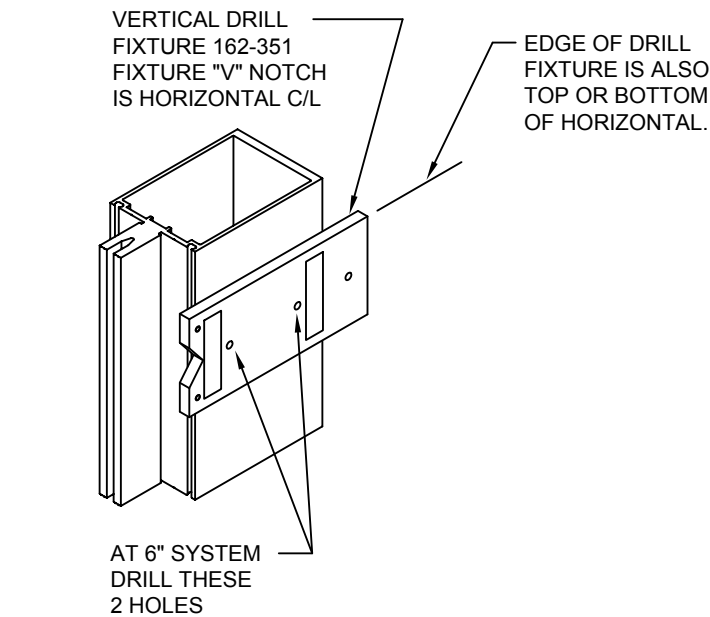
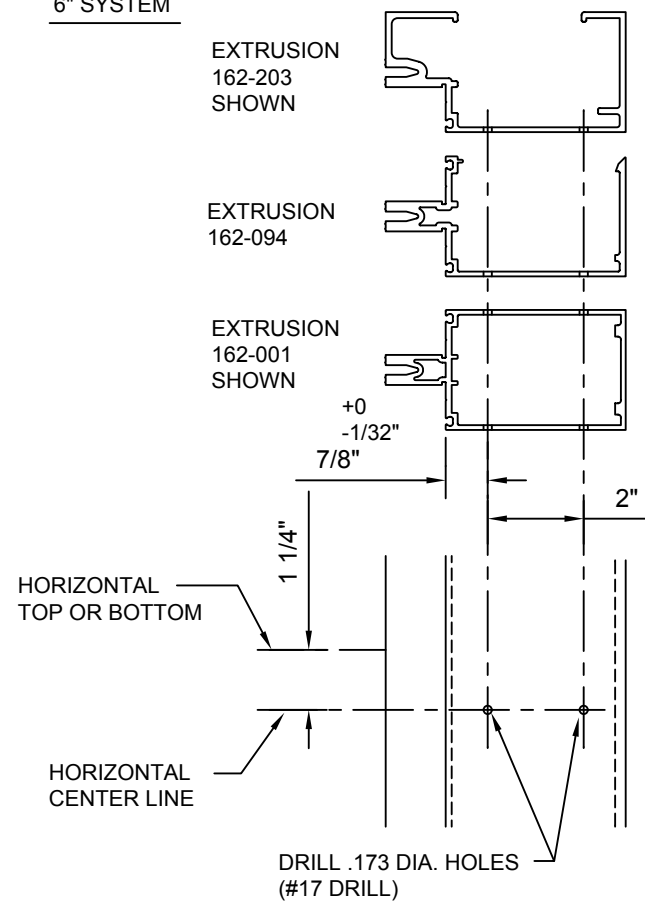

AT 6" SYSTEM  
DRILL THESE  
2 HOLES

### VERTICAL MULLION FABRICATION

REFERENCE APPROVED SHOP DRAWINGS FOR  
VERTICAL LENGTHS AND HORIZONTAL LOCATIONS.  
SPLICE FIXNG SCREW, STOP SCREW AND JAMB  
SIDE F-ANCHOR ALIGNMENT PREPS ARE ALL  
SIMILAR TO PREPS NOTED BELOW. REFERENCE  
SHOP DRAWINGS AND 162-970 INSTRUCTIONS.

7-1/2" SYSTEM

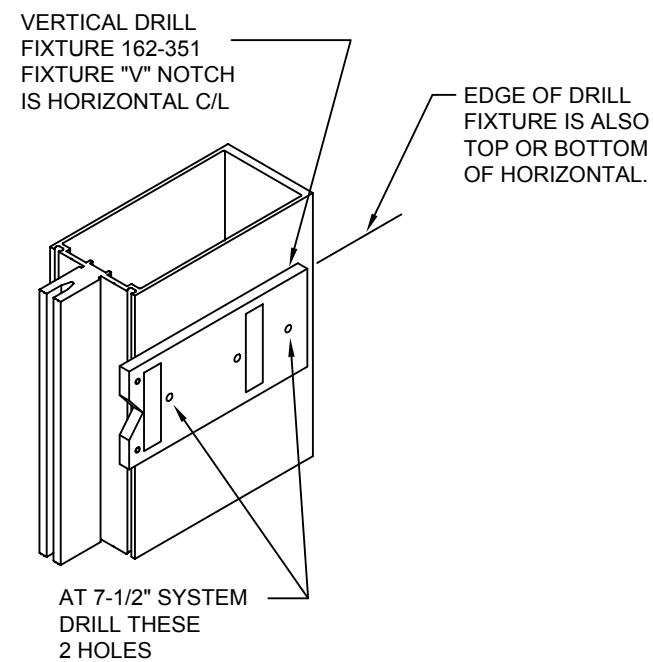
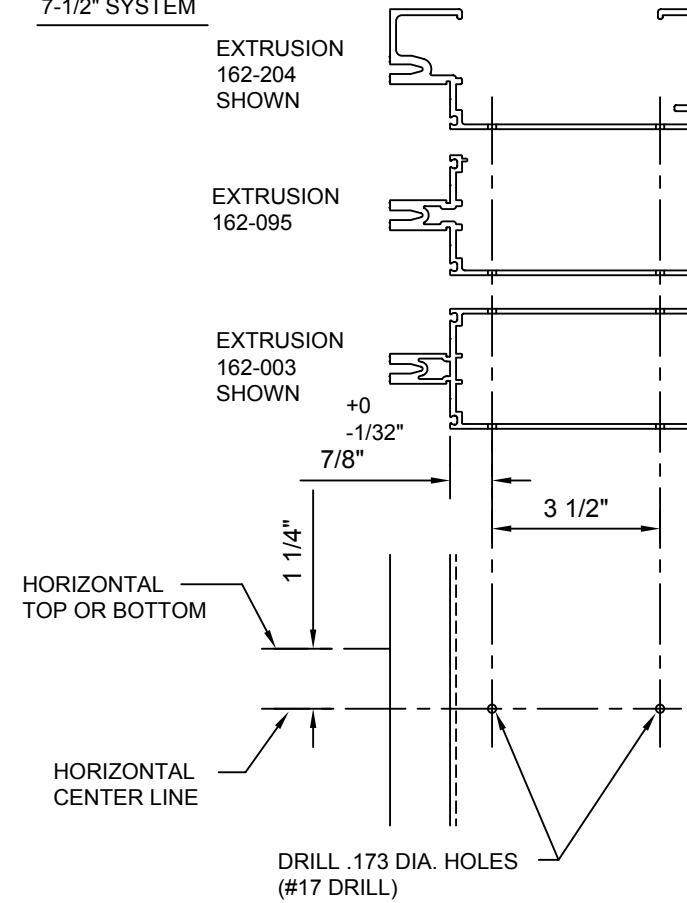

AT 7-1/2" SYSTEM  
DRILL THESE  
2 HOLES

### VERTICAL MULLION FABRICATION

REFERENCE APPROVED SHOP DRAWINGS FOR  
VERTICAL LENGTHS AND HORIZONTAL LOCATIONS.  
SPLICE FIXNG SCREW, STOP SCREW AND JAMB  
SIDE F-ANCHOR ALIGNMENT PREPS ARE ALL  
SIMILAR TO PREPS NOTED BELOW. REFERENCE  
SHOP DRAWINGS AND 162-970 INSTRUCTIONS.

10-1/2" SYSTEM

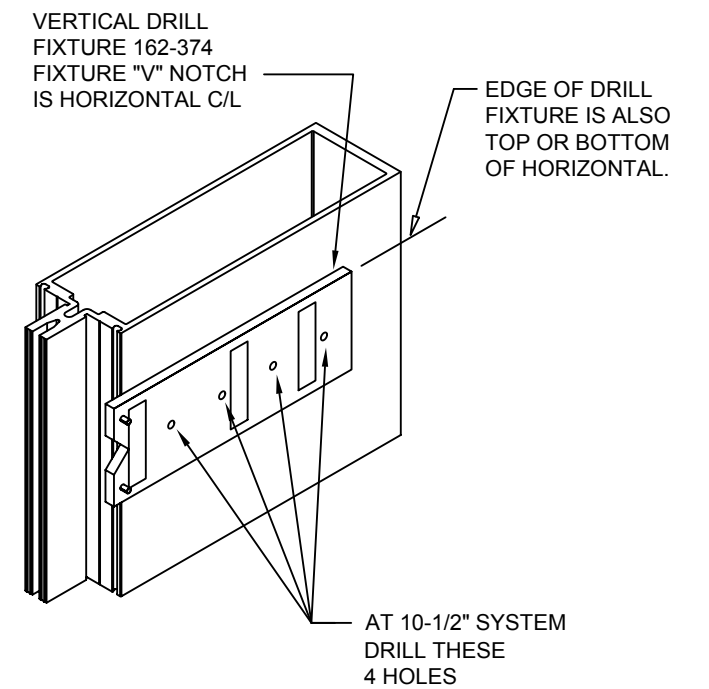
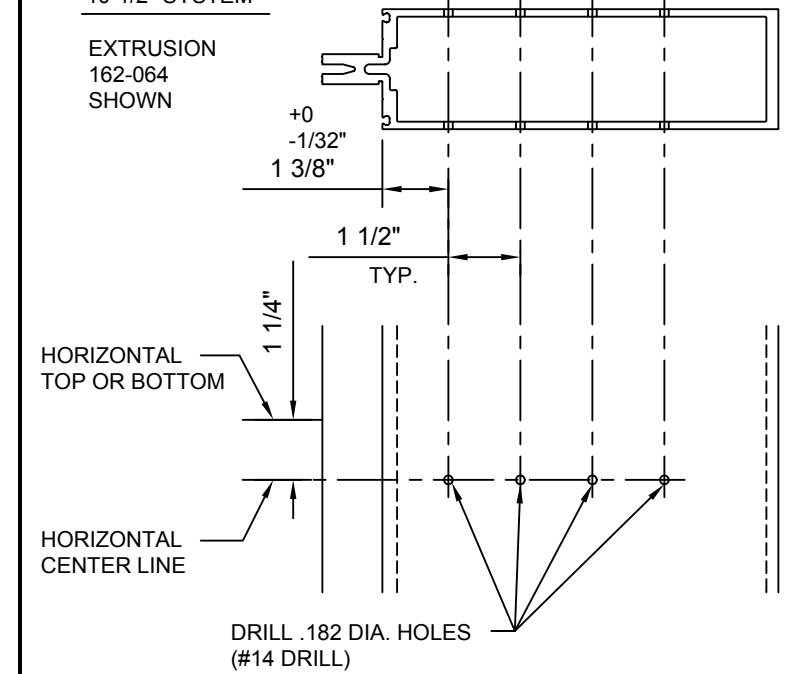

AT 10-1/2" SYSTEM  
DRILL THESE  
4 HOLES

**KAWNEER**  
1600 SYSTEM<sup>1</sup>  
STOCK LENGTH INSTRUCTIONS

PART NUMBER  
162-960 3 OF 5

95449-87  
02/17/12  
DRAWING:  
ORDER:  
SHT:

### HORIZONTAL FABRICATION

HORIZONTAL AND OPEN BACK FILLER LENGTH EQUALS DAYLITE OPENING MINUS 1/32".

6", 7-1/2" AND 10-1/2" SYSTEMS

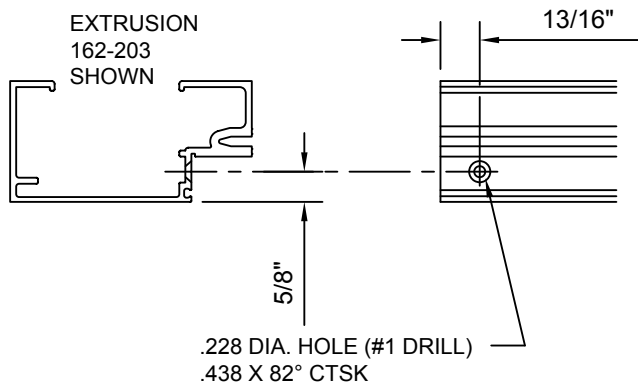
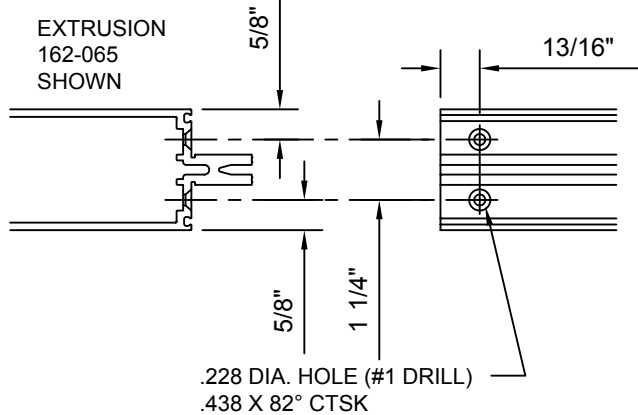
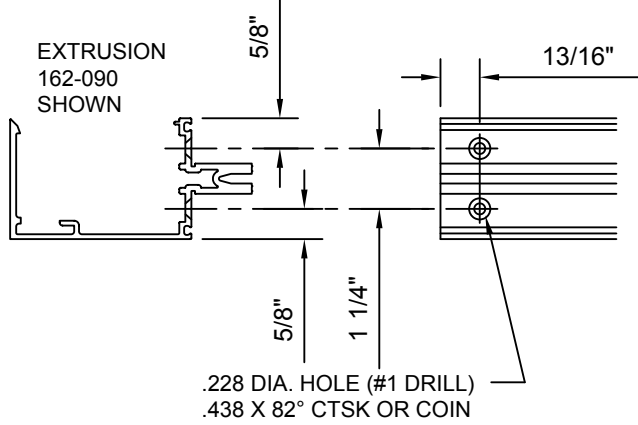
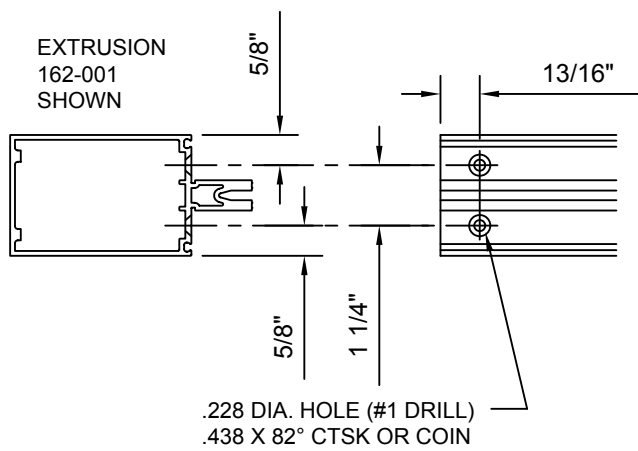

### HORIZONTAL FABRICATION

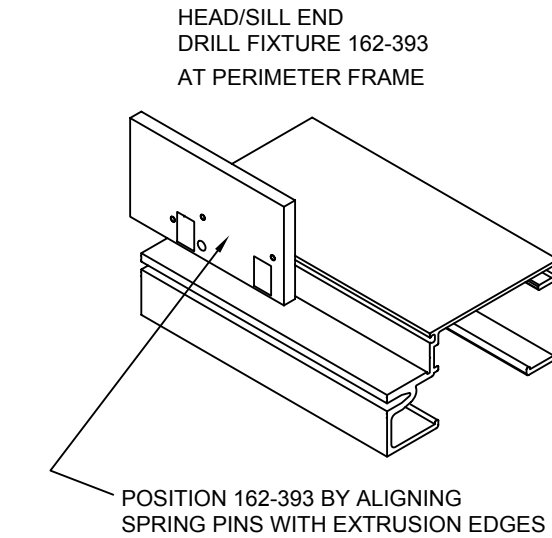
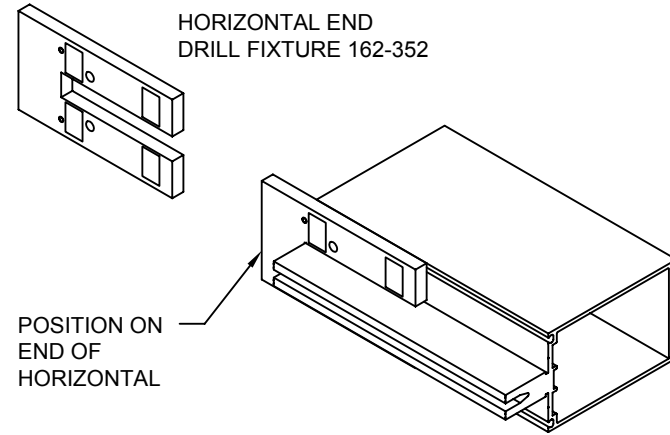

#### ADDITIONAL SHEAR BLOCK PREP FOR 10-1/2" SYSTEM

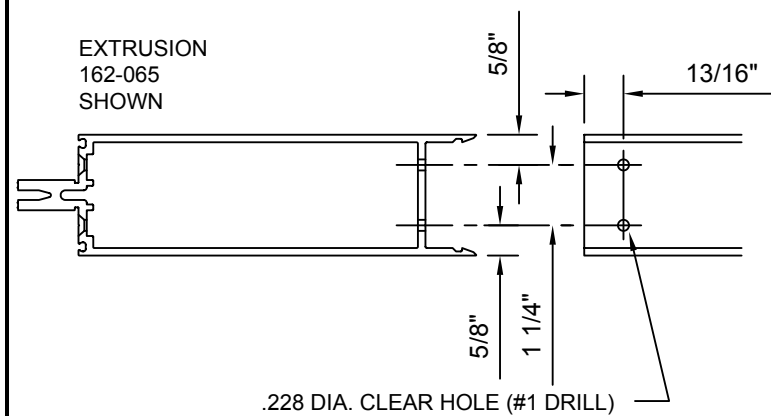

### HORIZONTAL FABRICATION

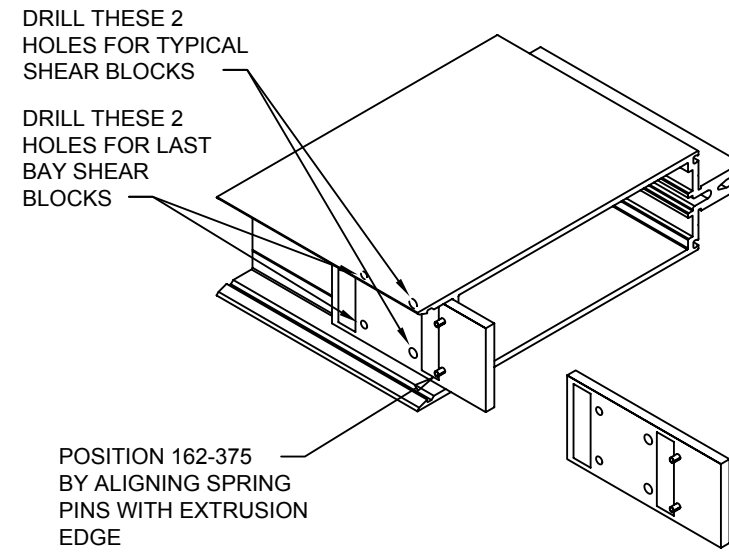

#### ADDITIONAL LAST BAY SHEAR BLOCK PREP AND NOTCH FOR 10-1/2" SYSTEM

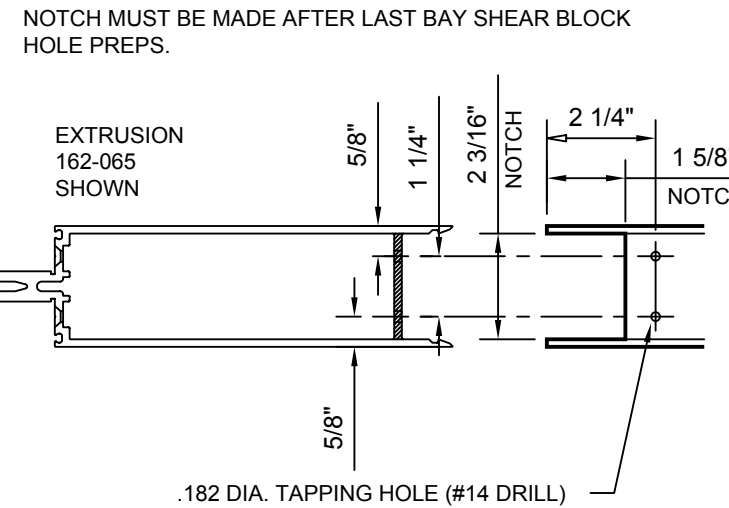

### HORIZONTAL FABRICATION

OPEN BACK HORIZONTAL NOTCH FOR "F" SHEAR BLOCK AT TYPE "D" ANCHORING.

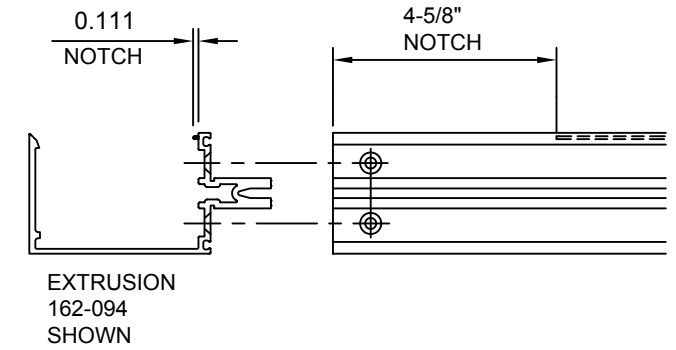

TUBULAR HORIZONTAL NOTCH FOR "F" SHEAR BLOCK AT TYPE "D" ANCHORING.

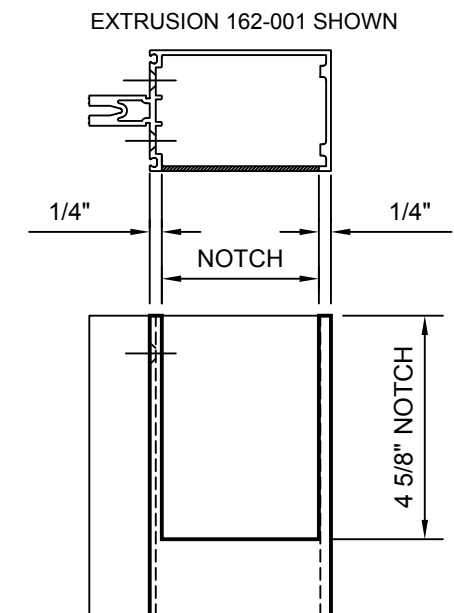

1600 SYSTEM<sup>1</sup>  
STOCK LENGTH INSTRUCTIONS

PART NUMBER 162-960 4 OF 5

95449-87  
02/17/12

DRAWING:

ORDER:

SHT:

### HORIZONTAL FABRICATION

LAST BAY HORIZONTAL NOTCH FOR SHEAR BLOCK AT TYPE "B" ANCHORING.

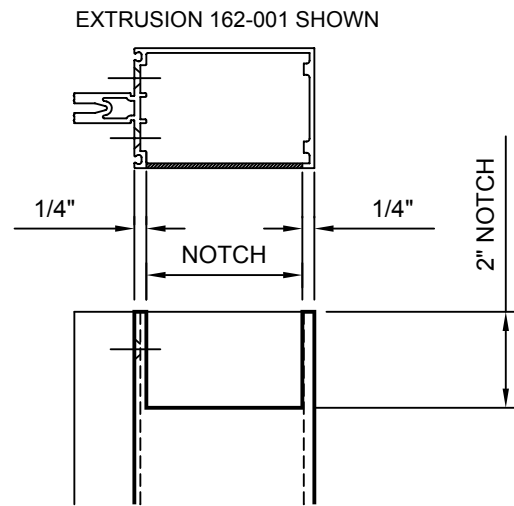

10-1/2" SYSTEM TUBULAR HORIZONTAL NOTCH AT TYPE "C" ANCHORING.

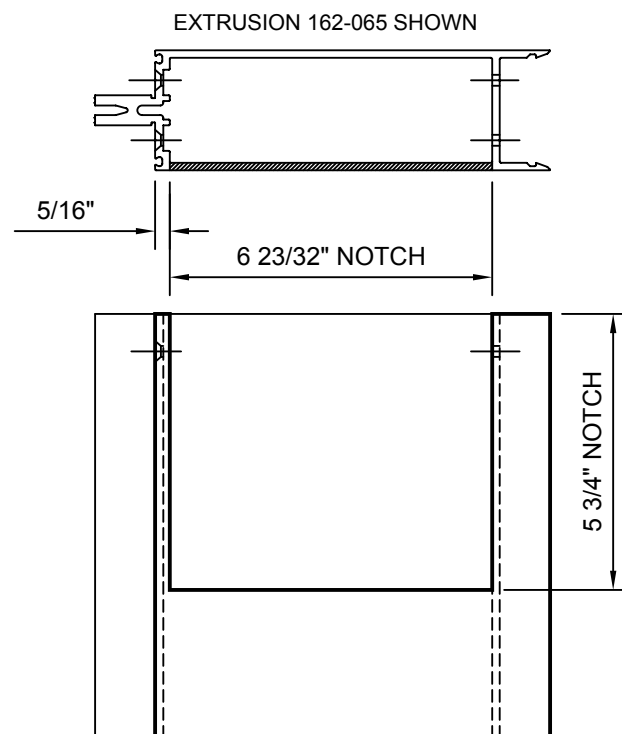

### ADAPTER FABRICATION

SPANDREL ADAPTERS

ADAPTERS ARE SQUARE CUT

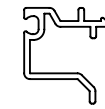

HORIZONTAL ADAPTER LENGTH EQUALS DAYLITE OPENING MINUS 1/16"

EXTRUSION 162-019

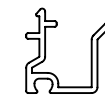

VERTICAL ADAPTER LENGTH EQUALS DAYLITE OPENING PLUS 1-3/8"

EXTRUSION 162-019

BELOW A VERTICAL SPLICE, VERTICAL ADAPTER LENGTH EQUALS DAYLITE OPENING PLUS 3/16"

### PERIMETER FABRICATION

VERTICAL MULLION NOTCH FOR "F" PERIMETER AT TYPE "A" ANCHORING.

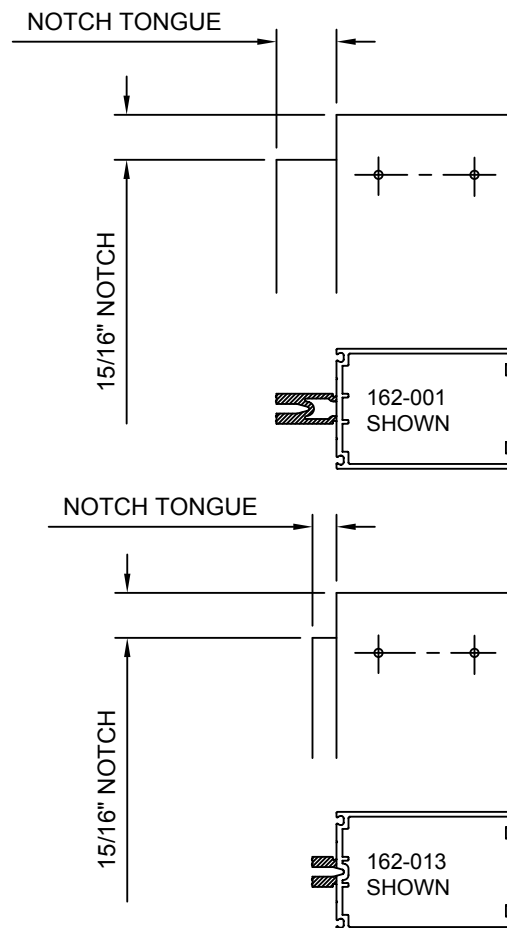

### PERIMETER FILLER FABRICATION

PERIMETER FILLER NOTCH BOTH ENDS ALL HEAD AND SILL FILLERS.

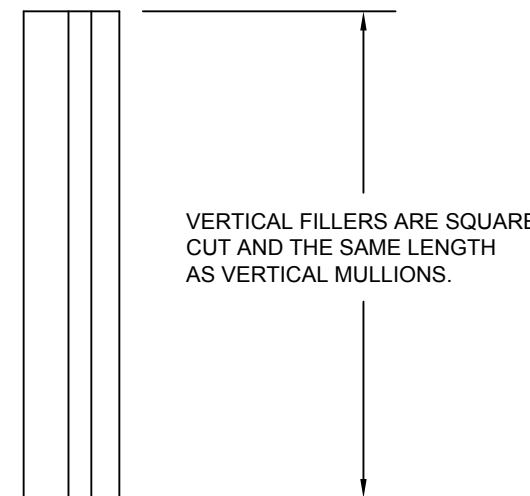
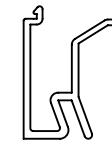
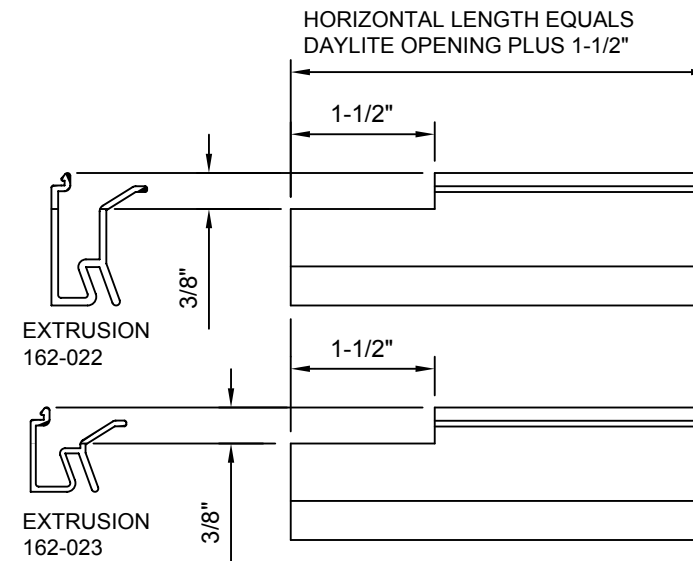

1600 SYSTEM <sup>1</sup>  
STOCK LENGTH INSTRUCTIONS

PART NUMBER  
162-960 5 OF 5

95449-70  
07/11/08

DRAWING:

ORDER:

SHT: